

# Stromgleichrichter NG 16 (Plattenaufbau)

SGA-16.

IZ-310-501-00

(Änderungen vorbehalten)

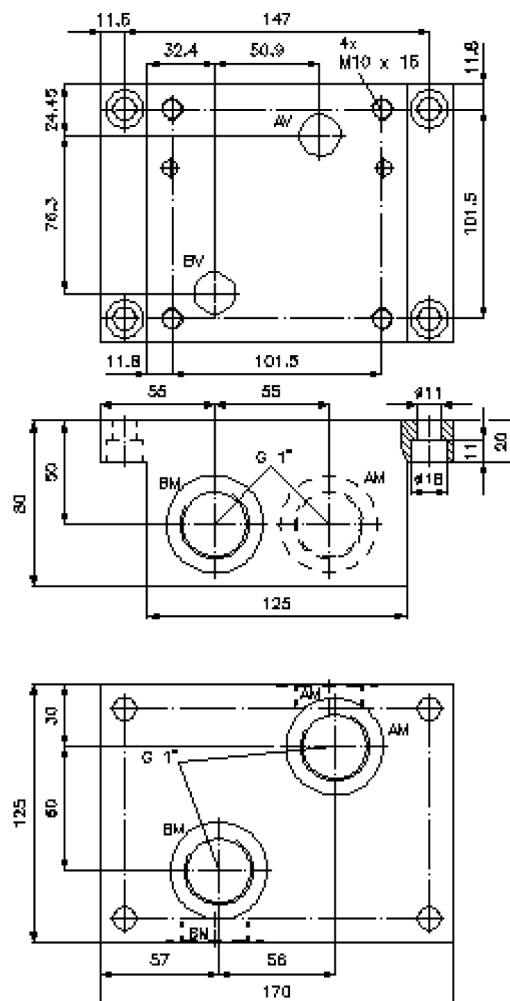
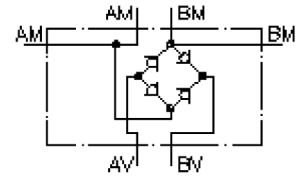

# Stromgleichrichter NG 16 (Plattenaufbau)

SGA-16.



Motrac Hydraulik GmbH  
Siemensring 87 - D-47877 Willich  
fon +49-(0)2154-8162.0 - fax +49-(0)2154-8162.499  
e-mail info.miw@motracindustries.com  
internet www.motracindustries.com

IZ-310-501-00

(Änderungen vorbehalten)



## Bestell-Beispiel:

SGA - 16A



## Typen-Schlüssel:

**A** **Geräteausführung**  
Stromgleichrichter-Platte  
Plattenaufbau

**B** **Baugröße und Werkstoff**  
16A = Alu (F37)  
16S = Stahl (9SMnPb28K bzw. GGG-40)

## Technische Daten:

**Nenndruck:** 250 bar (A)  
350 bar (S)

**Nennstrom:** 80 l/min

**Gewicht:** 3,9 / 10,7 kg (A/S)