

Senkbrems-Lasthalte-Ventil NG 6 ((Zwischenplatte) in A+B (Federr. entl.))

SBLZ-06.-A+BPGC/..

IZ-520-255-00

(Änderungen vorbehalten)

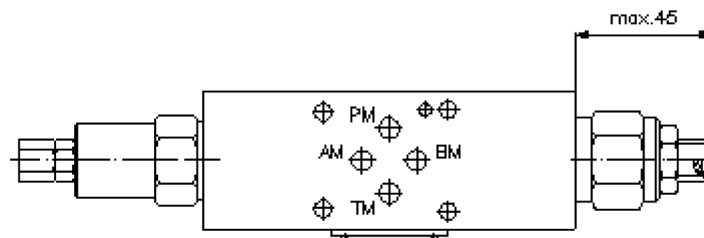
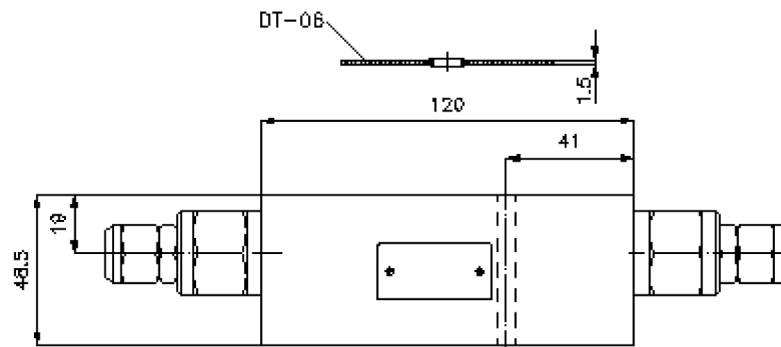
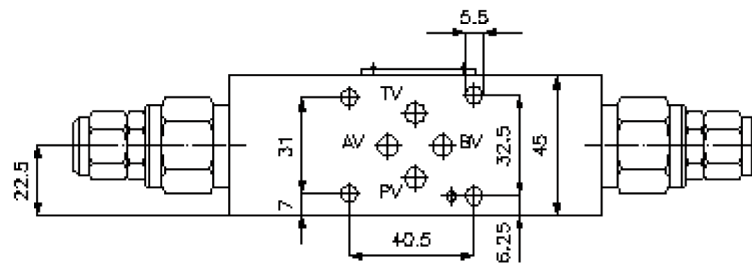
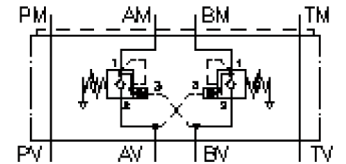

Senkbrems-Lasthalte-Ventil NG 6 ((Zwischenplatte) in A+B (Federr. entl.))

SBLZ-06.-A+BPGC/..



Motrac Hydraulik GmbH
Siemensring 87 - D-47877 Willich
fon +49-(0)2154-8162.0 - fax +49-(0)2154-8162.499
e-mail info.miw@motracindustries.com
internet www.motracindustries.com

IZ-520-255-00

(Änderungen vorbehalten)



Bestell-Beispiel:

SBLZ - 06A - A+B PG C / 50
| | | | | |
A **B** **C** **D** **E** **F**

Typen-Schlüssel:

- | | |
|---|---|
| <p>A Geräteausführung
Senkbrems-Lasthalte-Ventil
mit Lochbild DIN 24340 Form A
Zwischenplattenbauweise</p> <p>B Baugrösse und Werkstoff
06A = Alu (F37)
06S = Stahl (9SMnPb28K bzw. GGG-40)</p> <p>C Ausführungsfunktion
A+B = in A und B wirkend</p> | <p>D Senkbremsventil (Öffnungsverhältnis 4:1)
PG = CBPG-10.-.. (Federraum entlüftet)</p> <p>E Einstellart
C = Verschlusskappe
S = Schraubenspindel</p> <p>F Druckstufen (CBPG)
15 = 7,0 - 105 bar
30 = 21,0 - 210 bar
50 = 35,0 - 350 bar</p> |
|---|---|

Technische Daten:

- Nenndruck:** 350 bar (S)
250 bar (A)
- Nennstrom:** 60 l/min
- Gewicht:** 1,1 / 2,4 kg (A/S)
- Senkbrems-Lasthalte-Ventil:** CBPG-10.-.. siehe Massblatt-Nr.: [CC-420-101-00](#)
- Zum Lieferumfang gehören:** DT-06 = Dichtungsträger mit einvulkanisiertem O-Ring (Viton FPM)